

Dissemination of domestic biogas in China: status, strengths and weaknesses

Prof. Zhang Mi

Managing Director, Chengdu Energy-Environment
International Corporation (CEEIC)

Presented at the Biogas Meeting in Dhaka,
Bangladesh and sponsored by SNV, Netherlands

26-27 March, 2007

1. Current Status

☞ The development of the household biogas digester model in China

☞ The biogas dissemination and development prospect in China

1.1 The development of the biogas digester model in China

The end of 19th century

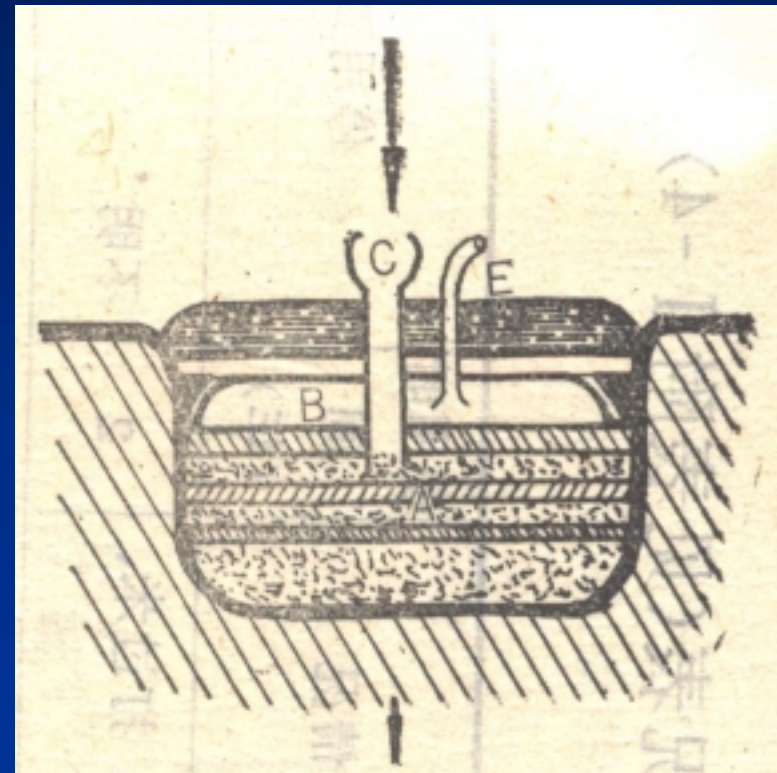
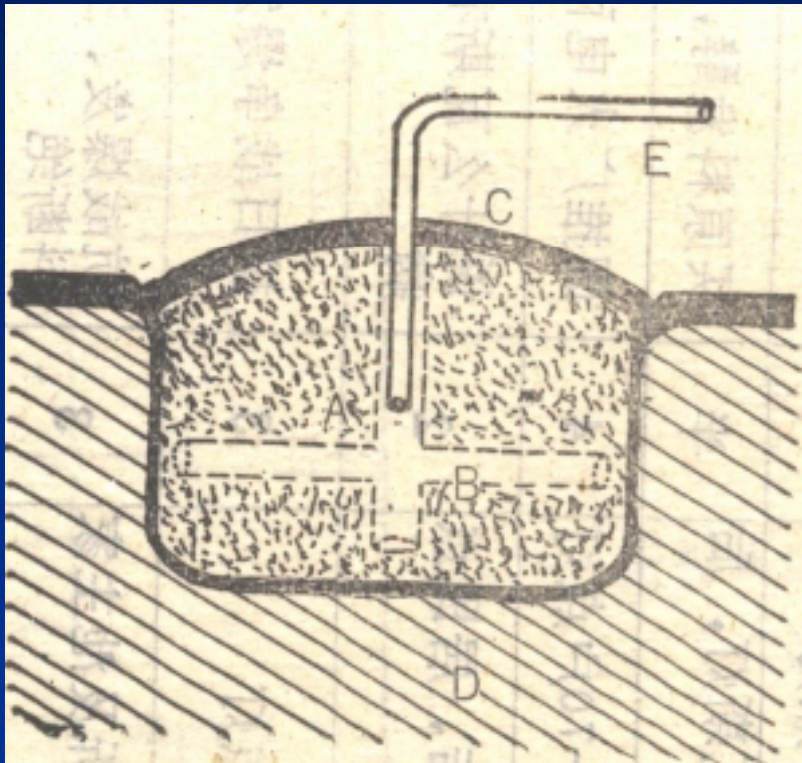

1.1 The development of the biogas digester model in China

In the 1920's

Luo Guori's digester

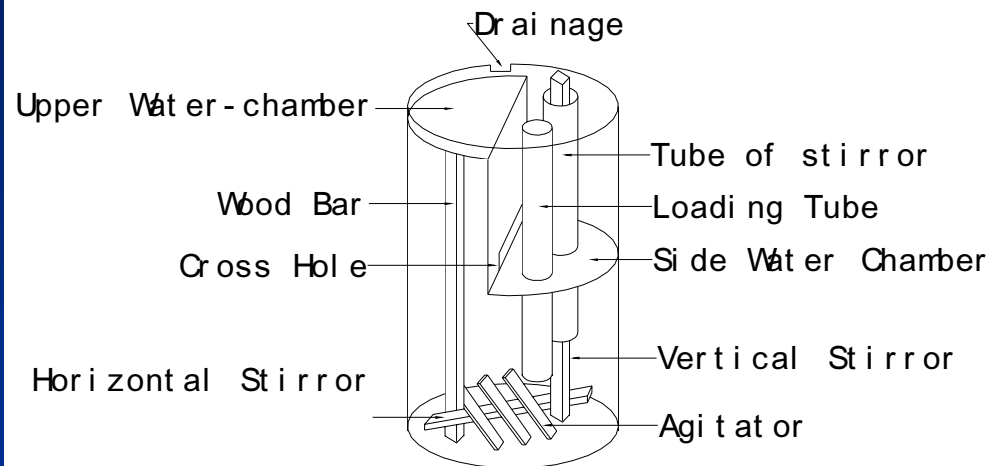
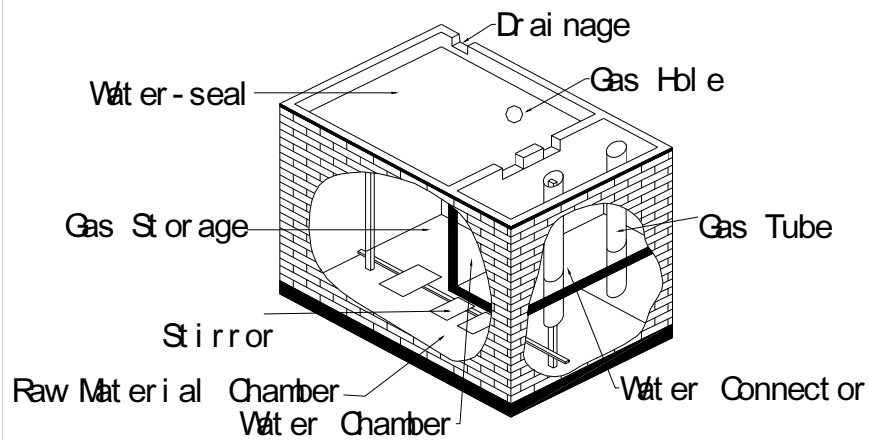

1.1 The development of the biogas digester model in China

In the late of 1970's

Hydraulic biogas digesters

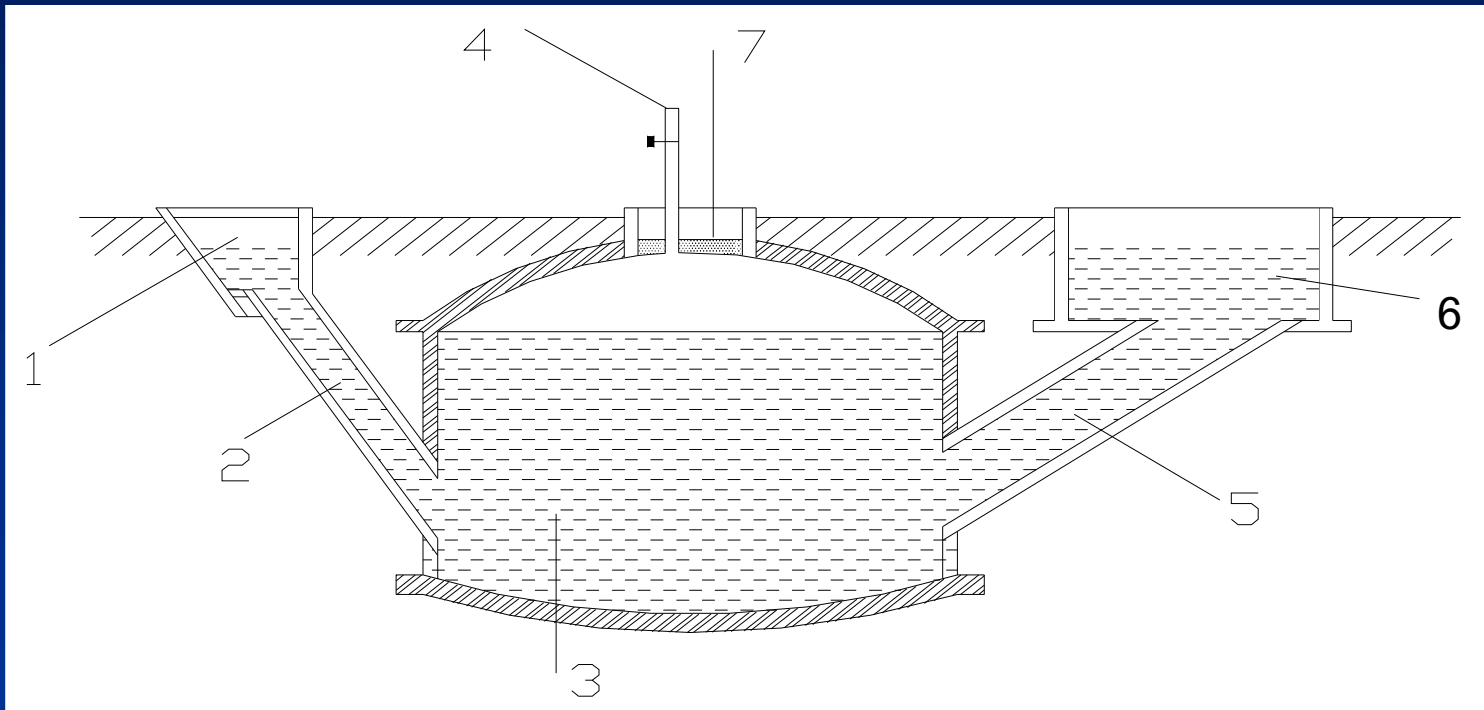

1 .Inlet; 2. Inlet pipe; 3.Fermentation chamber; 4. Gas pipe;
5. Outlet pipe; 6.Hydrulic chamber; 7. Movable cover

1.1 The development of the biogas digester model in China

Up to the 1990's small and high-performance biogas digesters

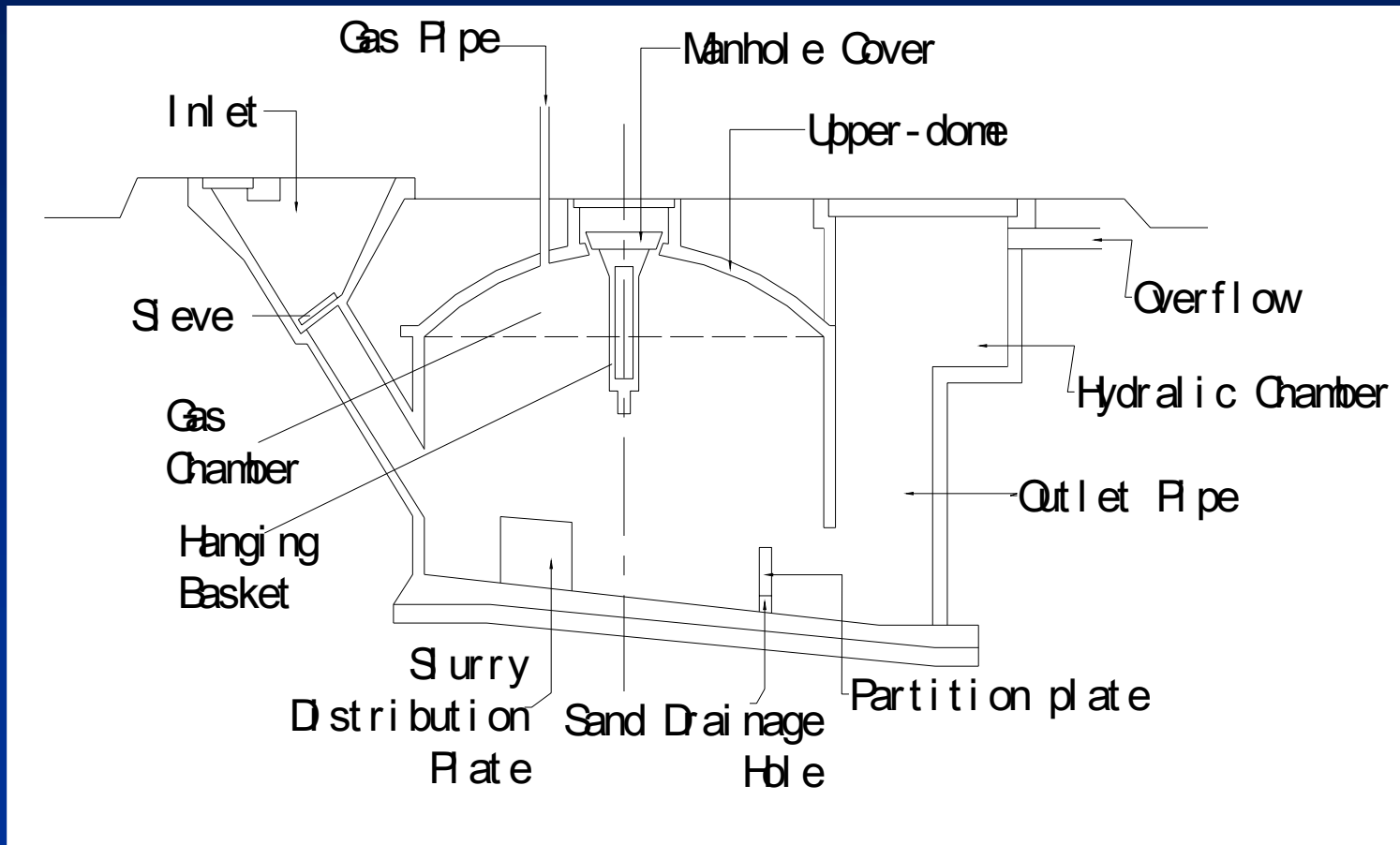

1.1 The development of the biogas digester model in China

In 2000, Commercialized biogas digesters of glass fiber reinforced plastic



1.2 The biogas dissemination and development prospect in China

Since the 1970's biogas development in China has taken four periods:

1973-1983, swift development and fall

1984-1991, adjustment and stressing science and technology

1992-1998, rebound and benefits appearing

1999 onwards, full speeding up and quick development

The development of biogas in rural areas of China

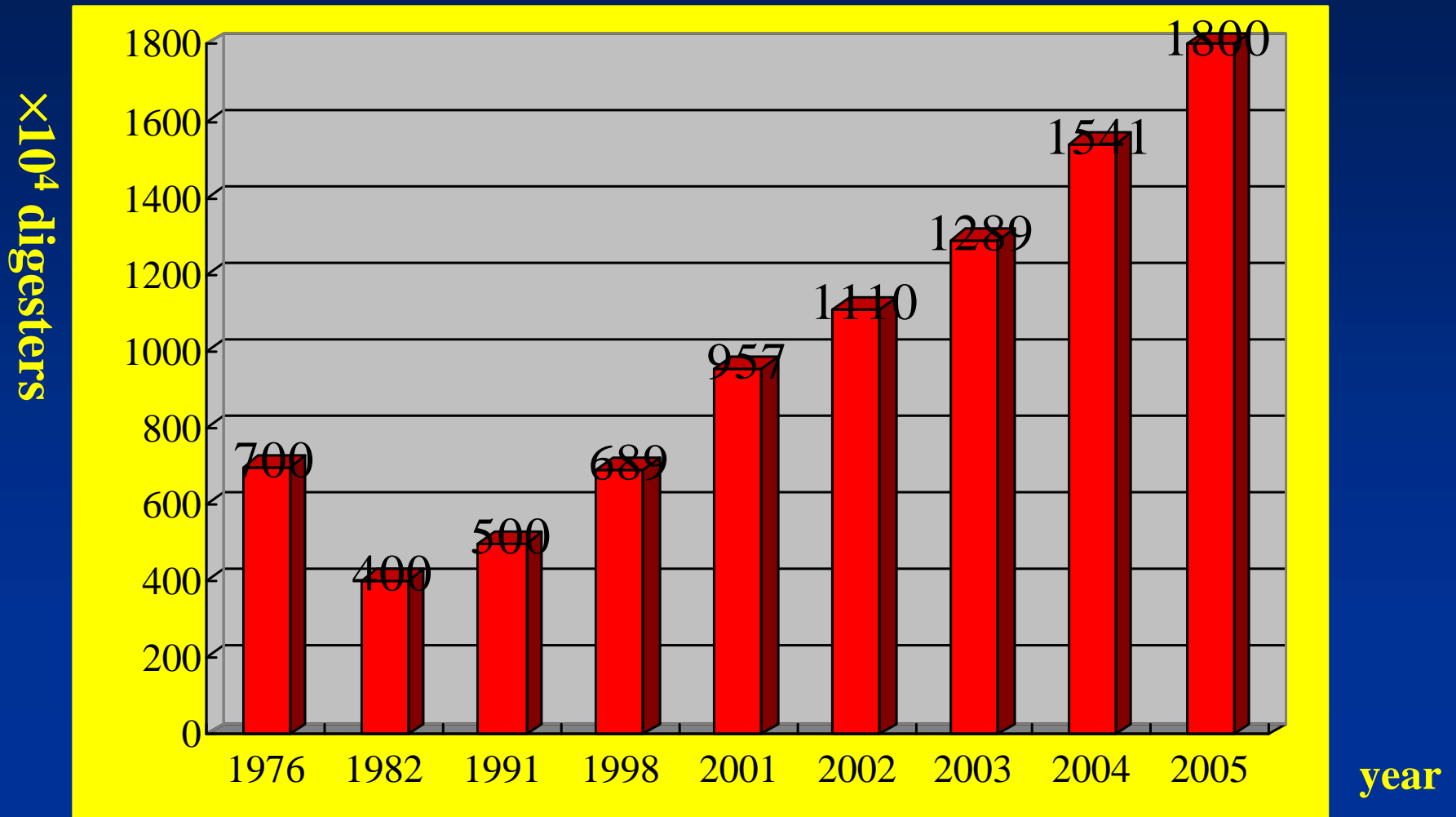

Currently a total of more than 18 Million rural household biogas digesters could produce 6.9 Bn Nm³ of biogas annually.

China is currently the largest dissemination country of domestic biogas program in the world

Restarting in the 1950s mainly at rural household level for the purpose of rural household energy supply, applying small-scale appropriate technology, China has currently the world largest dissemination of small scale biogas digesters in the volume range of 6-10m³, treating household animal manure, organic household wastes plus toilet content and waste water for the generation of biogas, which is used for heating, lightning and cooking.

Chinese Rural Household Biogas Digesters in Recent Years

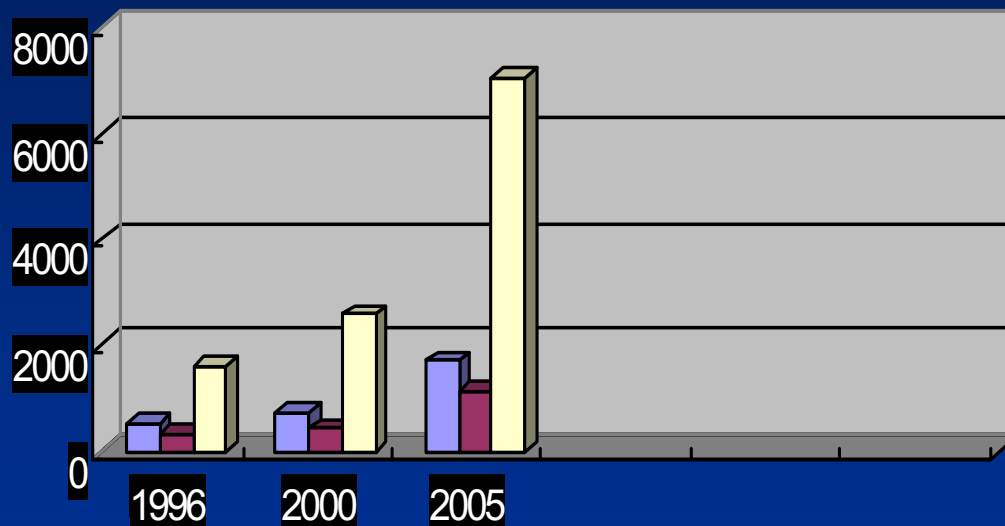

- 沼氣池用戶數 (萬戶) number of household biogas plant (x 10,000)
- 綜合利用用戶數 (萬戶) number of integrated utilization (x 10,000)
- 沼氣量 (100立方米/天) biogas output (100 M3 per day)

Chinese Rural Household Biogas Digesters in Recent Years

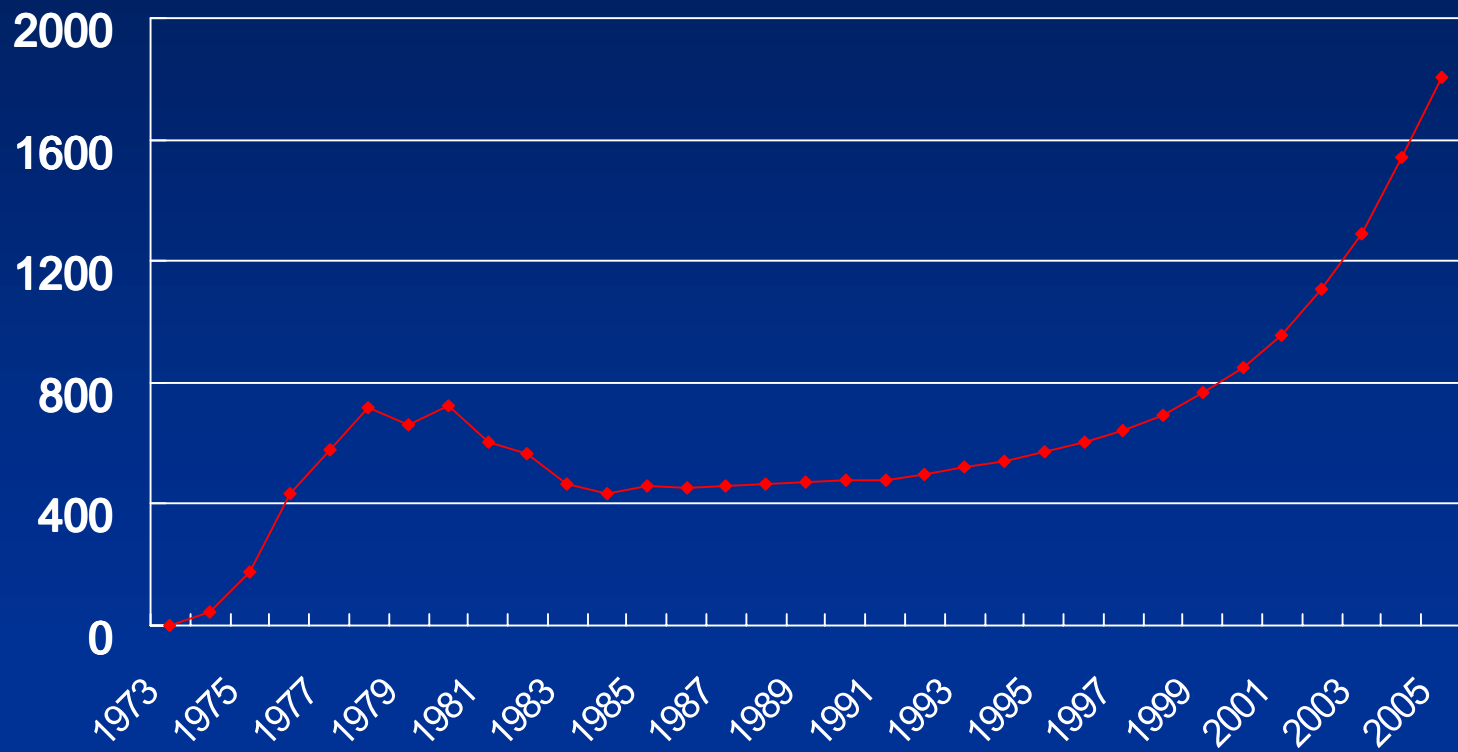

1.2 Distribution of household biogas digesters in China

Out of the 34 provinces of China, 31 provinces have introduced rural biogas digesters. Among these, 16 provinces have built more than 200,000 units.

Sichuan is the province with the largest distribution and 3.4 million units with gas yield being 1.2 billion cu.m per year by the end of 2006.

Potential and prospect for household biogas digesters in Sichuan, China

- Total households: 19,200,000
- Potential for construction: 14,300,000
- By the year of 2006: 3,400,000
- By the year of 2010: 5,00,000
- By the year of 2020: 10,000,000

National program for domestic biogas digesters development

• Year	Quantity	Increased	Popularized rate (%)
• 2006	18 Mio		15.0
• 2010	39 Mio	21 Mio	32.5
• 2015	61 Mio	22 Mio	50.8
• 2020	84 Mio	23 Mio	70.0

1.3 A radical change on the government policy for dissemination of biogas development in rural areas in China

- --- In 2006, biogas dissemination in China for the first time, has been put as a part of rural infrastructure for new rural construction as stated in the Premier's Government Working Report i.e. "Strengthen the rural infrastructure, namely, road, biogas, water, electricity and communication etc."

- --- Based on the above policy huge amount of government (central and local) investment to dissemination of domestic biogas program as subsidy to the users;

- 2005 1 billion yuan
- 2006 2.5 billion yuan
- 2007 5 billion yuan

As a part of new rural construction

- --- For biogas in rural areas of China , it seems a combination of planning economic plus marketing economy. Without government investment (subsidy), it can not make such a big stride as government pays more attention on the integrated benefits than only economy;
- --- Back to the early 1990's, the relation between market economy and biogas dissemination seemed unbalanced, which caused a little drop of digester quantity as people stressed more economy than the other benefits at that time;

1.4 Fermentation technology

The normal temperature for fermentation is between 10—25°C, the feedstock is human and animal waste with crop waste as well . Semi-continuous fermentation process is widely adopted in the vast rural areas of China.

1.5 Digester structure

The Majority of the household digesters are of fixed dome type. The different construction models are cylindrical, spherical, or ellipsoid. The construction material are bricks, stone and concrete with some other newly developed building materials like reinforced glass fiber plastic as well .

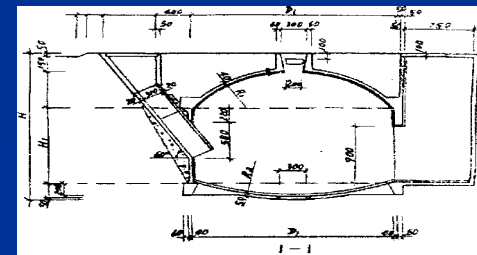

Household biogas plant- construction



s
e
c
u

1.6 Use of biogas and appliances



d
d
a



1.3 Overview of the use of bio-slurry in China

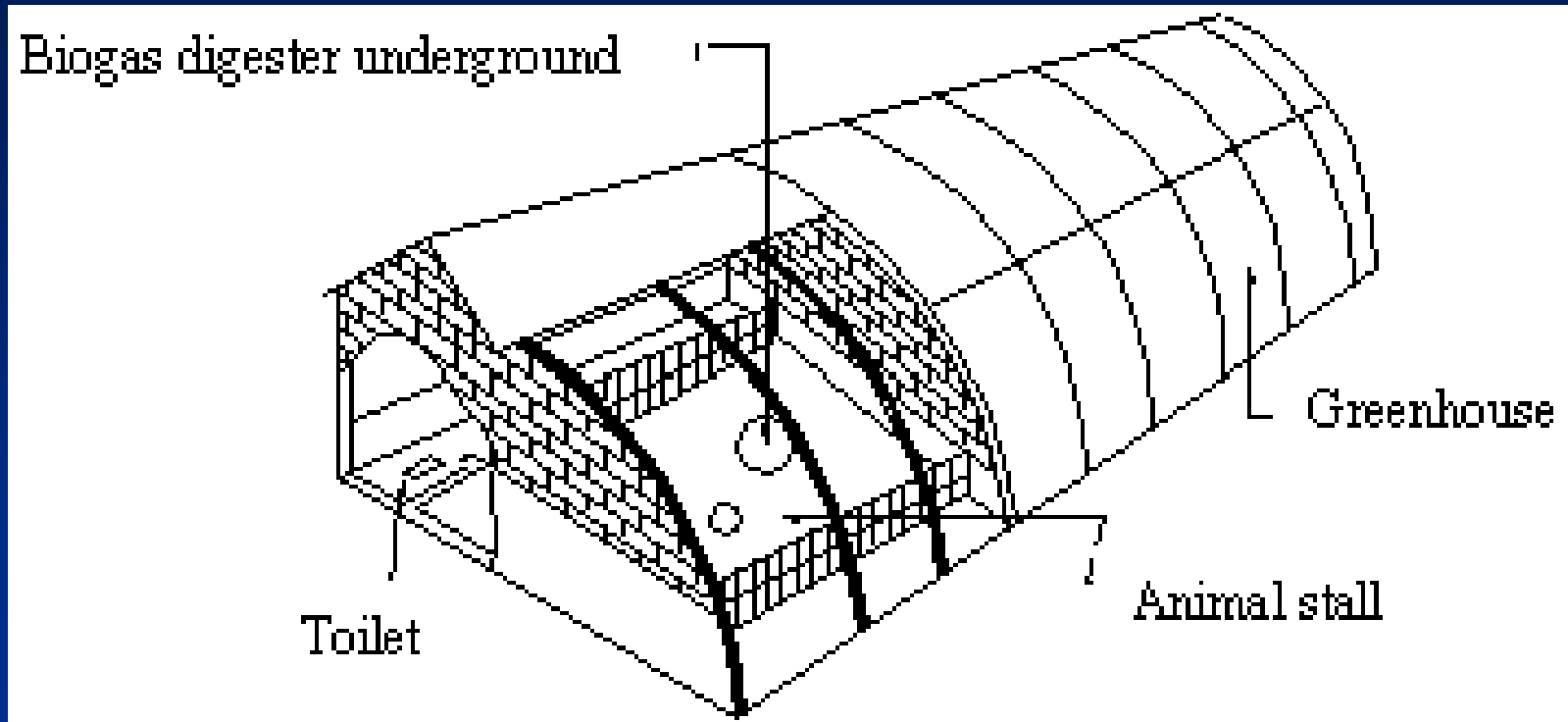

“Four-in-One” biogas model

Greenhouse, vegetable, pig stall and biogas digester

1.3 Overview of the use of bio-slurry in China

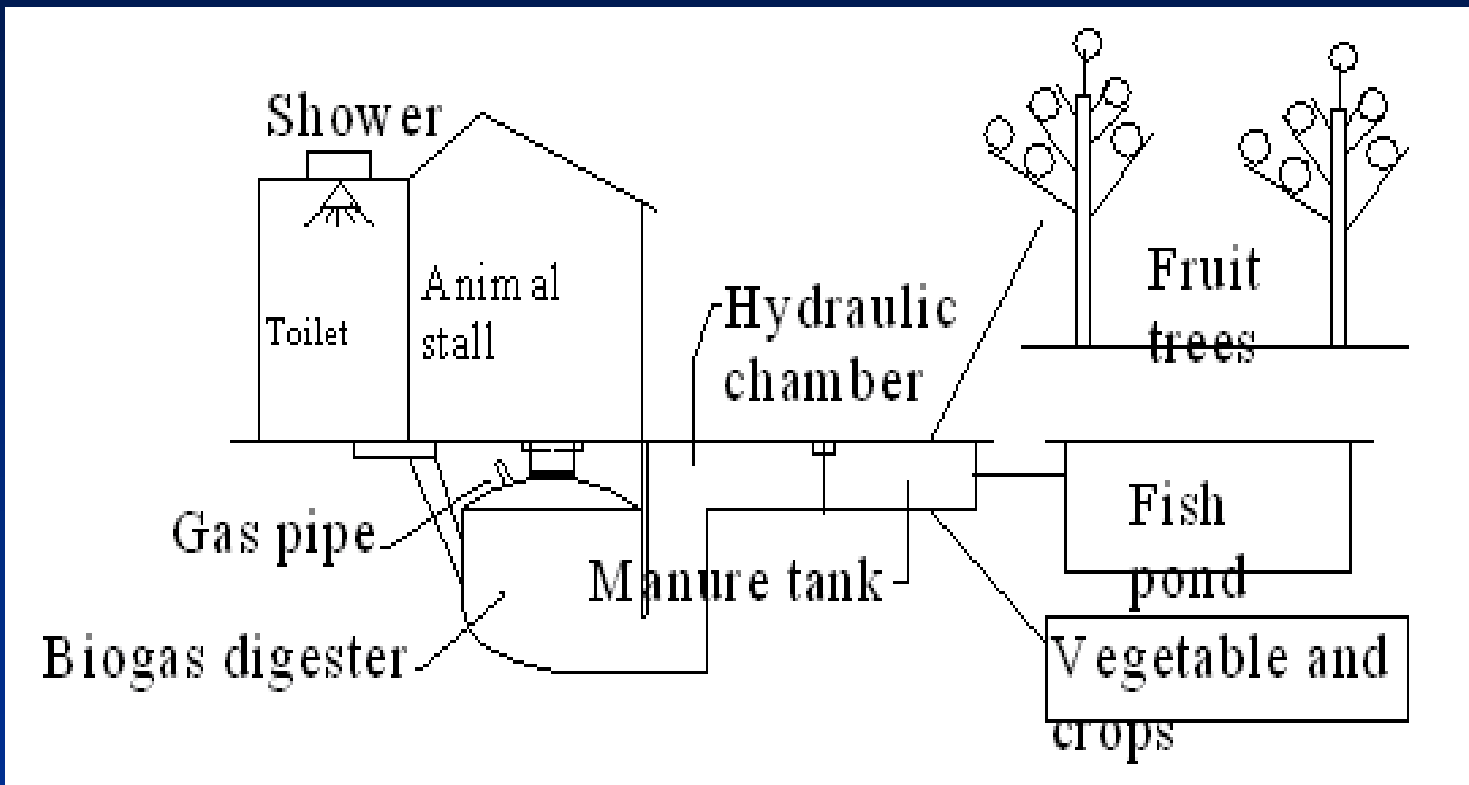

“Pig sty - Biogas digester - Fruit trees” Model
Animal husbandry- Biogas digester- Plantation

1.3 Overview of the use of bio-slurry in China

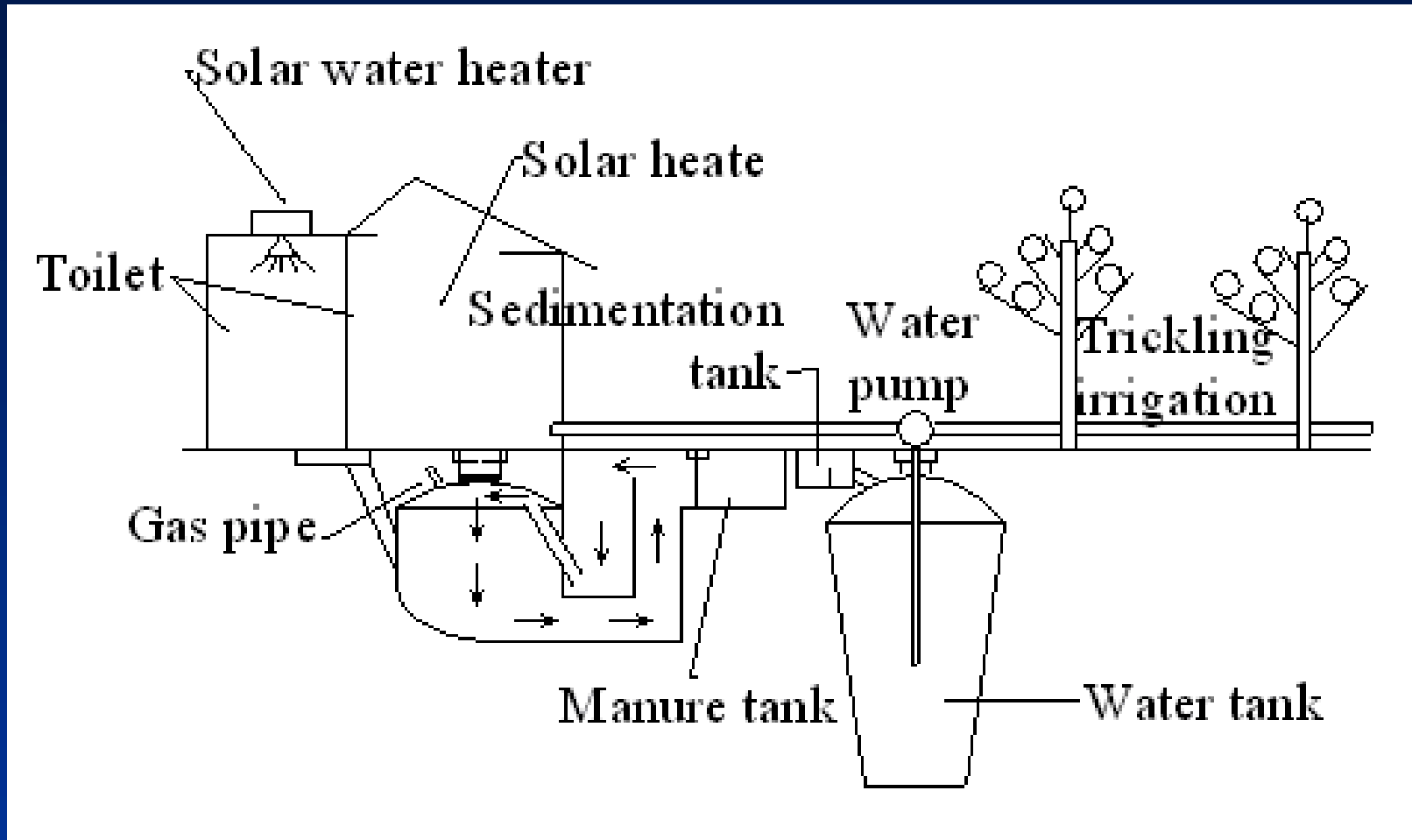

“Five--in—One” Eco-Orchard System

Digester, solar heater, animal stall, water stove & fruit garden

6. Integrated Utilization of Biogas

- In 2005, national biogas integrated utilization households reached by 6.7309 million households , occupying 37.3% of the digester implemented households, obtaining increment in agriculture, beneficiary, as well as the incomes of farmers



Crops, trees, shrubs
作物、树木、灌木



Feed 饲养

Livestock 家禽



Family 家庭



Excreta 排泄物

Biogas 沼气



Bio digester 消化器

Irrigation 灌溉

Pond 鱼塘



Effluent 沼液

The ecological farm
生态农场

Energy- ecology model

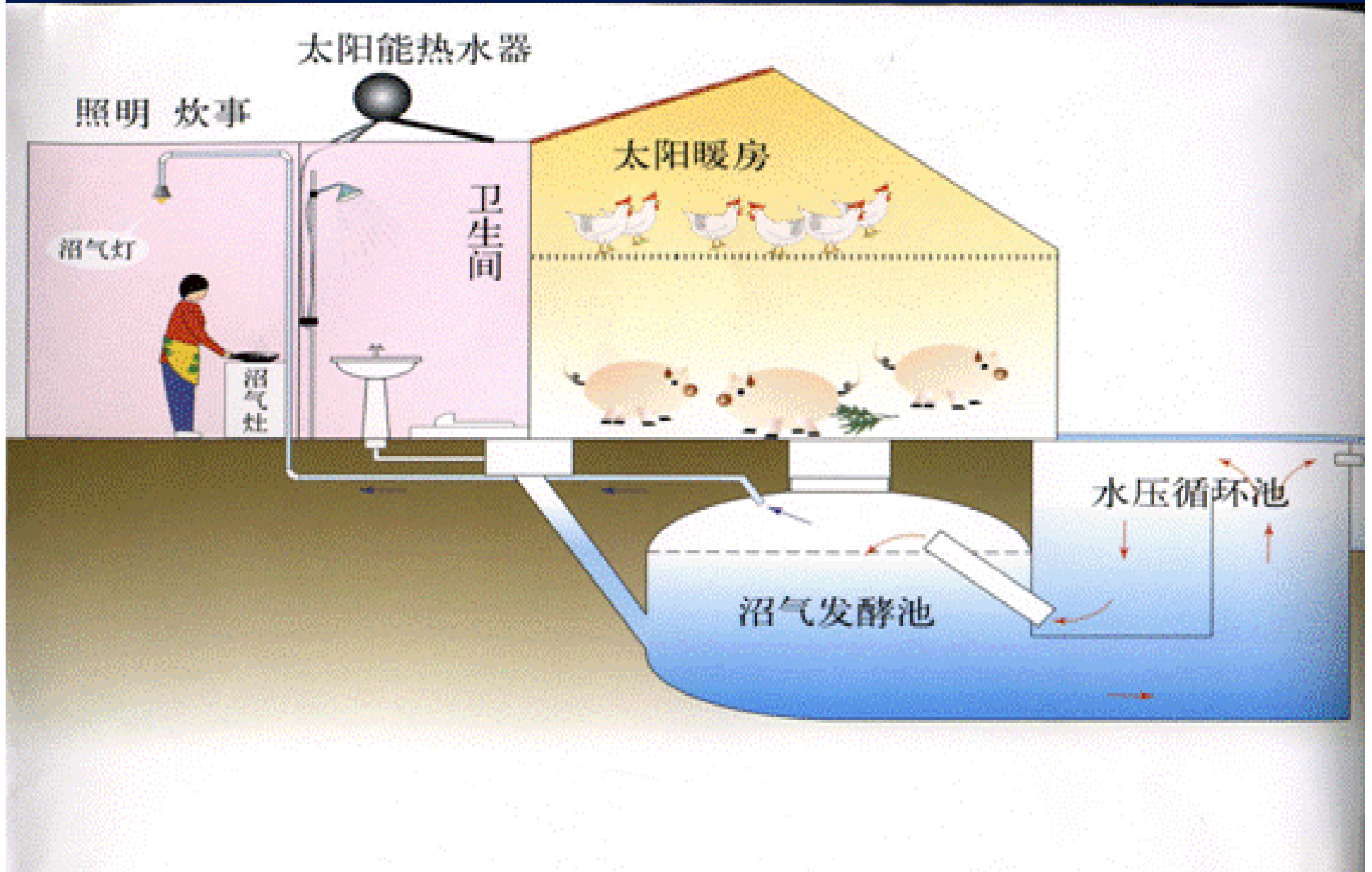

Ecological Fruit Courtyard Model

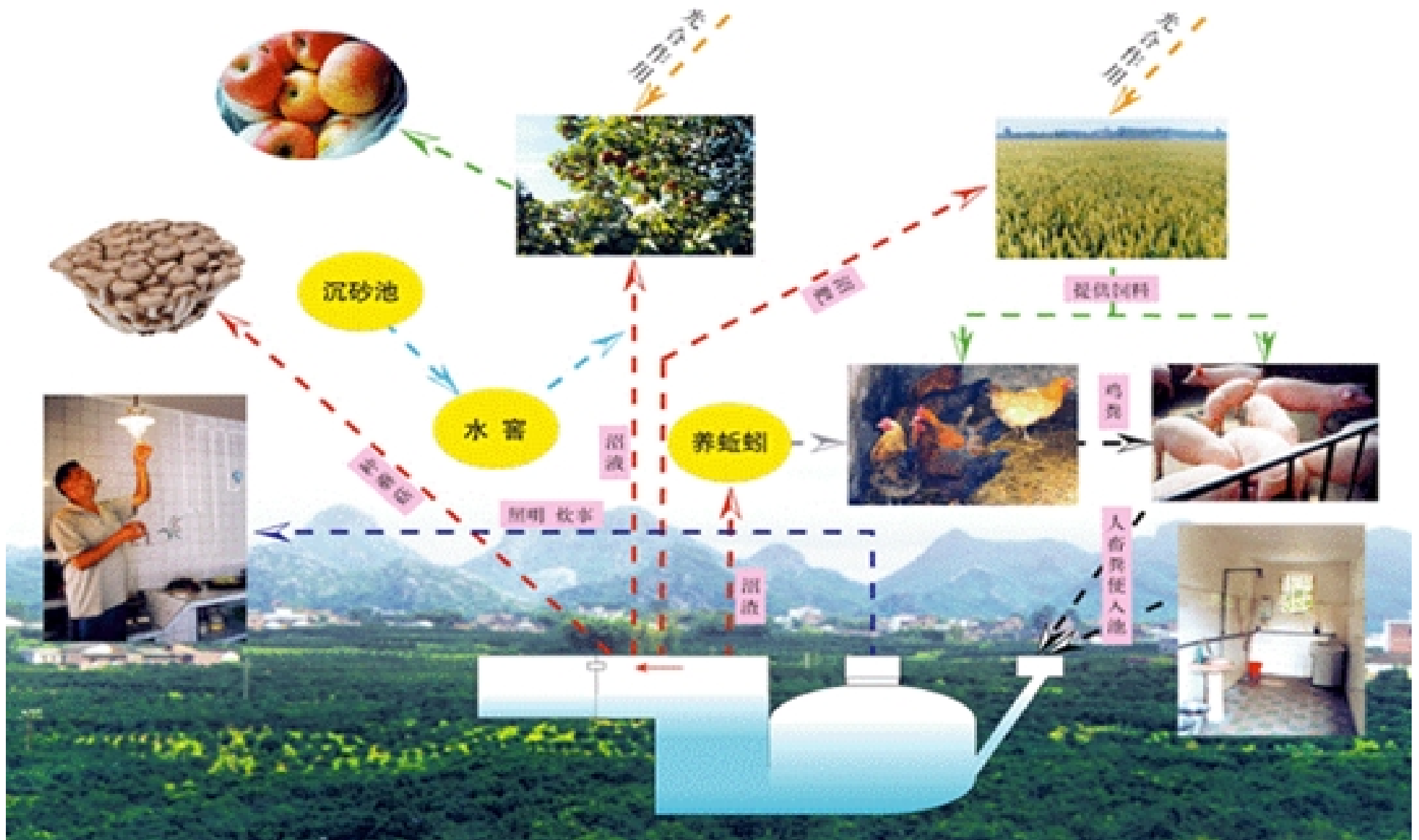

Biogas Integrated Utilization

温室能源生态模式

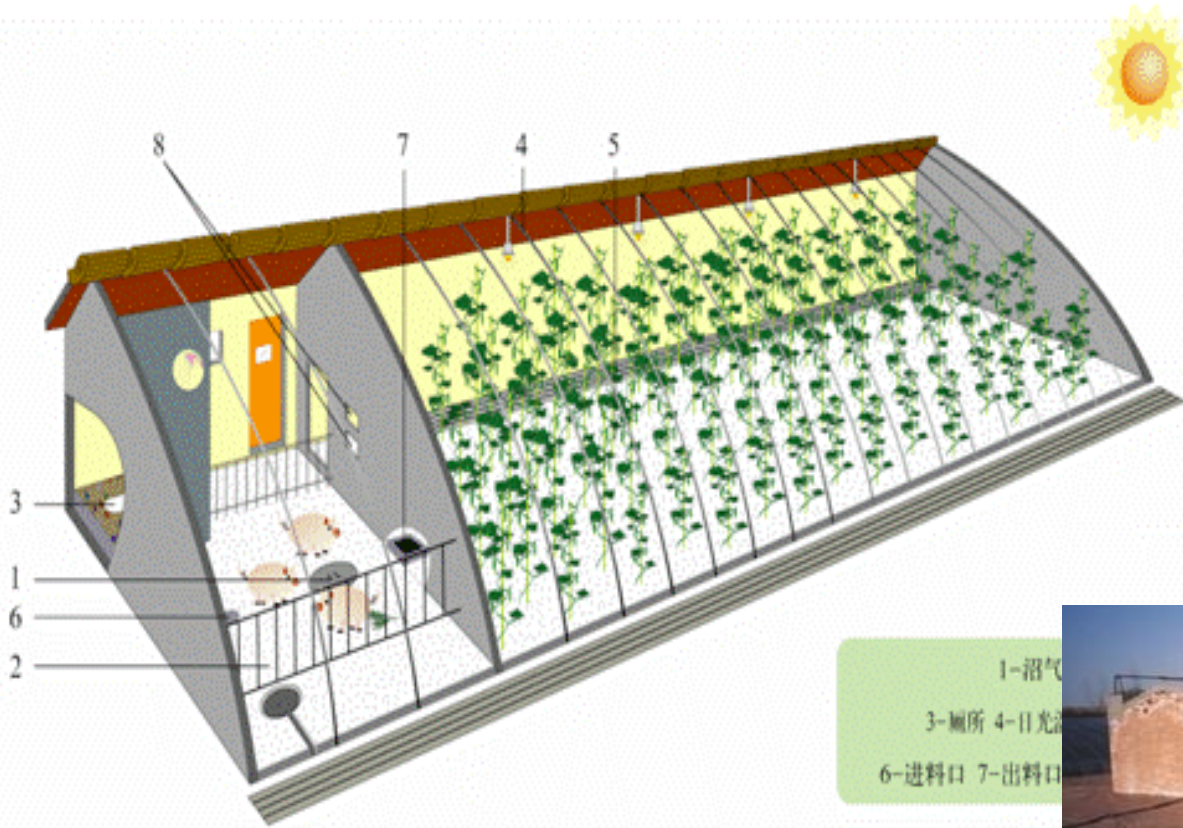

1-沼气管
3-厕所 4-日光温室
6-进料口 7-出料口



1.8 Situation by the end of 2005

	农业沼气工程 Agricultural Biogas Plants	工业沼气工程 Industrial Biogas Plants	总计 Total
Operating Quantity (unit) 农业沼气工程	3,556	208	3,764
Digester Volume (m ³) 池容	1,005,600	718,500	1,724,100
Waste Treatment Amount 废水处理量	87,109,400	35,710,000	122,820,000
Biogas Output (m ³) 沼气产量	229,851,100	111,291,300	341,142,400
Biogas Supply to Households (household) 用于家庭的沼气	131,981,500	6,384,700	138,366,200
Biogas Power Generation (kWh) 沼气发电量	8,726,228	31,721,317	40,447,545
Installed Capacity (MW) 装机容量	6.699	12.5	19.199
Commercial fertilizer 商品肥料	3,031,000	1,499,100	4,530,100
Commercial animal feed 商品饲料	37,800	722,600	760,400

2. Strengths

- 2.1 In view of political and institutional aspects, it is favorable and stable to biogas dissemination as the program is from the central government. And it is almost risk-free for the officials and implementers at all government levels as the policy is from central govt. and put into the govt. constitution and laws;

2.2 The policy brings big investment

- --- In the personal view domestic biogas program in China now seems a combination of product of planned economy in line with market economy.
- --- Tracing back to the early 1990's, market economy caused some drop of digester quantities due to many people only looking for economy but not environment and ecology etc.

2.3 Stressing more on science and technology

- --- Due to the govt. policy of large development and investment for rural biogas dissemination, attention is much more paid to science and technology, and training of personnel is also stressed.
- --- eg.500 biogas staff and technicians will be trained at BIOMA(BRTTC) sent by the MOA (Ministry of Agriculture), which is the amount of last 20 years in the institute.
- --- More funding for the R & D

2.4 Favorable for private small and medium enterprises to develop

- --- Biogas as a new industry will bring a lot of private enterprises to emerge and grow such as manufactures, construction companies and service stations as well;
- --- Biogas courses has being given at more and more schools and universities as compulsory course; eg. 3 Ministries like MOA, MOE (Ministry of Education) and MOH (Ministry of Health) jointly launched a Biogas Training Program at schools at different levels;
-

2.5 Providing more job opportunities

- --- The big quantity of biogas digesters to be built needs a large number of biogas engineers, technicians, teachers, skillful and unskillful labors, and workers for manufacturing such appliances , and management staff and workers to be more active as well;
- --- Research programs needs more scientific and lab workers;

2.6 Great impact on social and environment as well as ecology

- --- Rural energy situation and structure will be much improved;
- --- Farmers' income increased and their life is greatly changed with good sanitation;
- --- Organic farming in agriculture for sustainable development;
- --- Forestation protected and soil erosion much reduced;
- --- Contribution to CDM and world climate etc.

3. Weaknesses

- 3.1 Big stride in development may bring the problem of construction quality and management for the biogas digesters;
- 3.2 In some areas and provinces the local biogas offices pay much attention to the quantity target but not quality control;
- 3.3 Some users just want to get the favor of subsidy, after the completion of digester construction, it stands with lack of feedstock due to less animals as people go out to work;

3.4 Social awareness lags behind

- --- Lack of strong social propaganda;
- --- A great number of biogas staff and workers need training in technology and management;
- --- Users especially for women are lacking of biogas knowledge and know-how for the normal operation and daily management;

4. Suggestions

- --- Target for quantity completion should be in line with quality control;
- --- Training for large number of qualified personnel should be at different levels;
- --- Strengthen the R & D and social propaganda in different ways;
- --- Encourage private sectors to develop like manufactures for biogas appliances and construction companies as well as after sales service stations etc.

Thank you!

